

# BU1 In Counter Spec Sheet

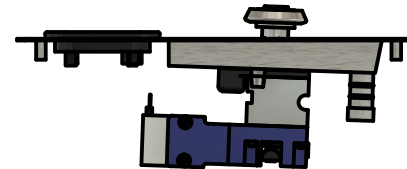
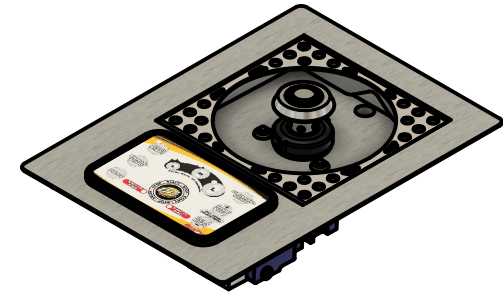
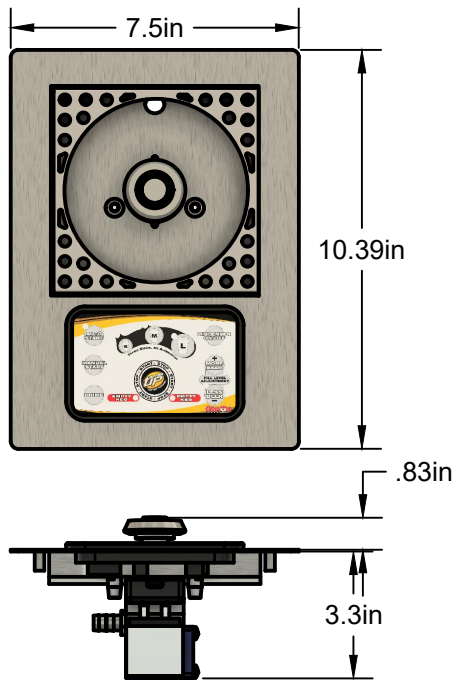

Dispenser needs a minimum clearance of 3.5" from top of counter to bottom of valve bodies. Underside of dispenser must be accessible for service work. Dispenser requires a standard 120VAC outlet within 10 feet of location.

All Bottoms Up Dispensers come with LEDs that light up the beer while filling, 6 feet of drain line, mounting hardware, spare o-rings, and user instructions.

In Counter Model	No Glycol Lines. Dispenser is intended to be mounted in the surface of a refrigerated keg box.
In Counter LONG DRAW	6 feet of Glycol line * and insulation are installed to accommodate a long draw installation. A cooling system MUST be connected into the glycol lines to keep the beer cold up to the point of dispense.

Dispenser Specifications	
Number of Valves	1
Beer Line	6 feet of $\frac{3}{16}$ " id vinyl *
Certifications	NSF # C0217099
Power Requirements	1 Standard 120VAC outlet @ 2 Amps
Power Supply Approvals	UL / CUL / PSE / TUV / BSMI / CCC / CB / FCC / CE



\*  $\frac{3}{16}$ " id vinyl line and high pressure glycol line may be increased up to 9 feet for long draw installations less than 50 feet or to accommodate for high elevation.

# BU1 In Counter Cut Dimensions

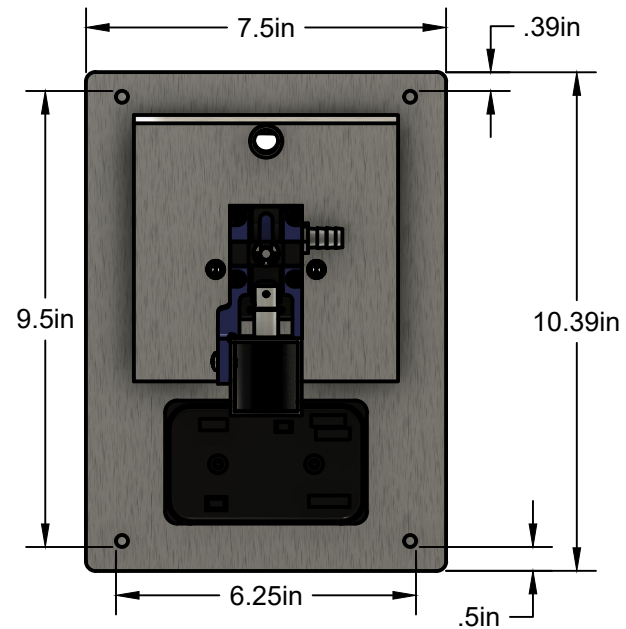

Minimum Cut Dimension is 6.25" X 9.5". DO NOT cut over 7.5" X 10.39".



# BU1 Tap Display Spec Sheet

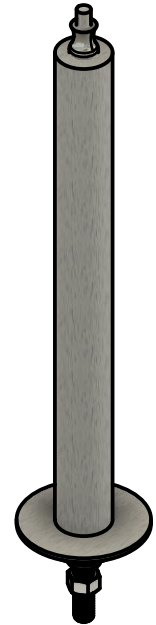
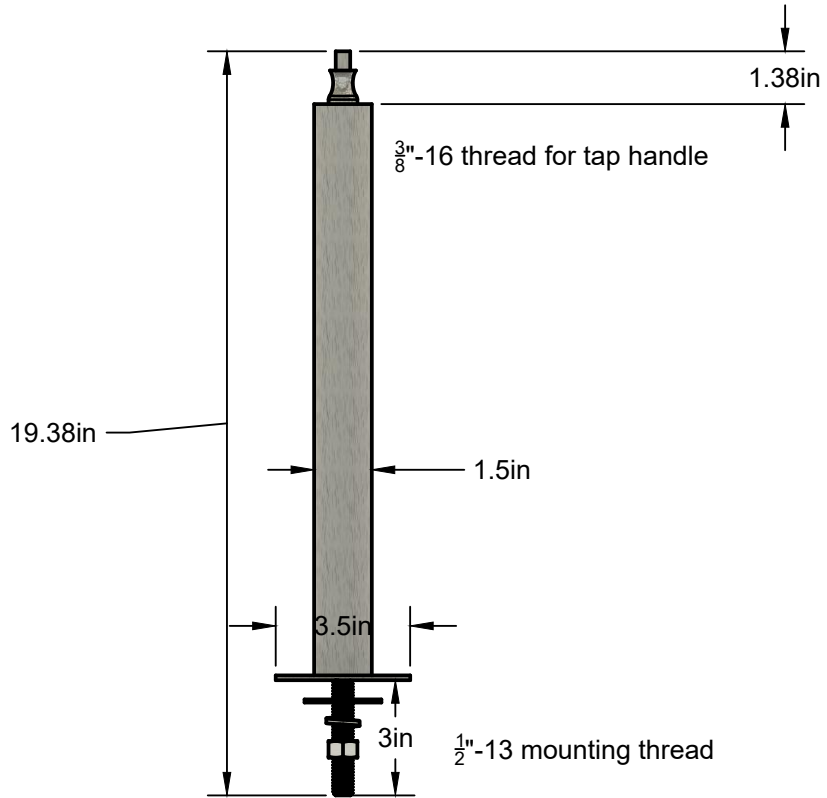

Tap Display is included with Dispenser.